

ESCALA: 6:1

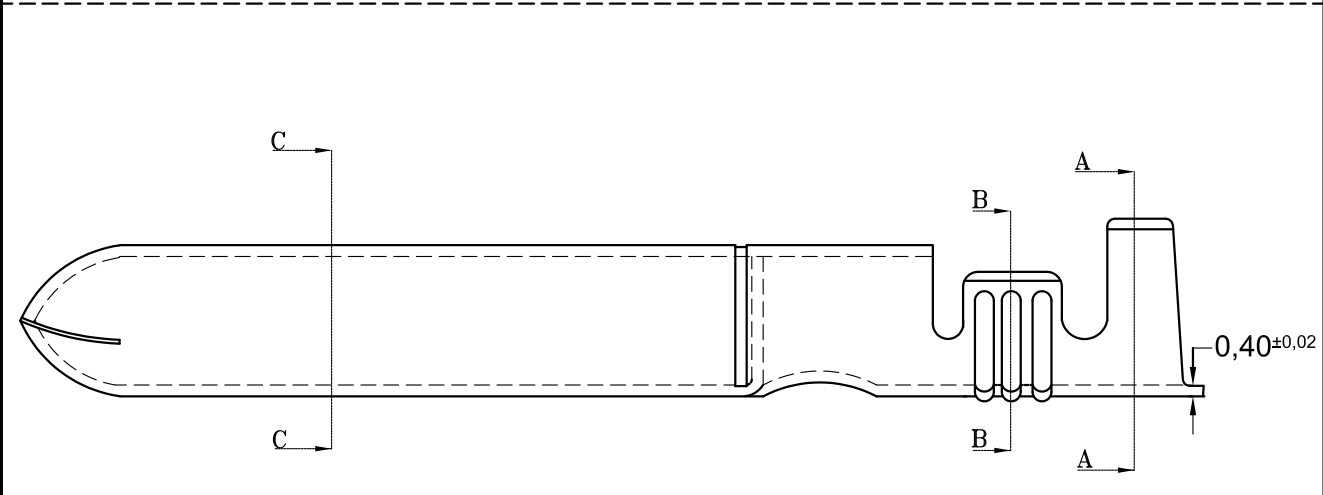

ESCALA: 5:1

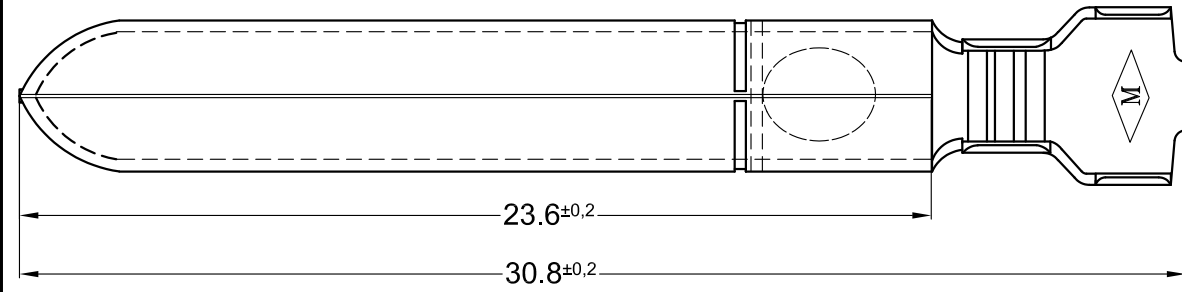

Plano sujeto a modificaciones sin previo aviso

PARA PRESENTACIÓN "SUELTOS", CÓDIGO SIN "C" FINAL				
CÓDIGO EN BANDA	MATERIAL	TERMINACIÓN	PIEZAS X CARRETEL	CANTIDAD SUELTOS
1.04.0925C	LATÓN CuZn 30	NATURAL	5000	2000
1.04.0927C	LATÓN CuZn 30	NIQUELADO		

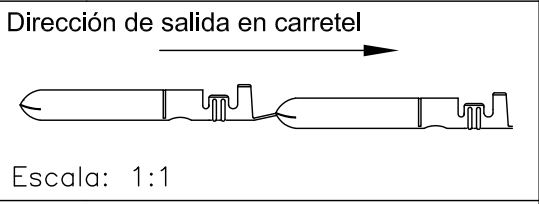

N° REVISIÓN/FECHA 00 1º EDICIÓN 09/06/92 01 COTA 23 ERA 3.2 --COTA 29 ERA 4.5--19/03/2019 02 CAMBIO FORMATO HOJA A4 - 04/02/2022	SECCIÓN COND.	METALGRAB S.R.L
	mm ² (AWG)	
	Ø AISLANTE	TERMINAL: CILINDRICO MACHO LARGO Ø 4 PLANO CLIENTE N° 0925
	2.1-2.8mm	